

YEAR 9 SCIENCE

EXAMINATION - SEMESTER 2, 2015

WRITTEN QUESTION AND ANSWER BOOKLET 2



**KINROSS
COLLEGE**

Believe · Act · Achieve

STUDENT'S NAME:

TEACHER'S NAME:

DATE:

TIME ALLOWED FOR THIS PAPER:

Reading time **before** commencing work: 10 minutes

Working time for this paper: 1 hour 50 minutes

MATERIAL REQUIRED / RECOMMENDED FOR THIS PAPER:

To be provided by the supervisor:

- This question and answer booklets

To be provided by the candidate:

- Pens, pencils, ruler, eraser

IMPORTANT NOTE TO CANDIDATES

No other items may be taken into the examination room.

It is your responsibility to ensure that you do not have any unauthorised notes or other items of a non-personal nature in the examination room. If you have any unauthorised material with you, hand it to the supervisor BEFORE reading any further. All iPads and mobile phones must be turned off and in your bag along with any other devices and notes. Bags are to be closed and placed under the desk.

INSTRUCTION TO CANDIDATES:

1. **Read** through the paper to familiarise yourself with all of the questions.
2. Use a **blue or black** ballpoint / ink pen for the written answers. Use pencil for drawing the graphs.
3. **Write** your answers in this booklet.
4. Should you require more space than you have been given please use **the spare sheet** (at the back of this booklet) and ensure that you include your name and the question / statement to which you are responding.

AT THE END OF THE EXAMINATION:

- Any planning sheets or other pieces of paper **MUST** be handed in with this booklet.
- At the end of the examination make sure that your name is on your booklet and any other pieces of paper used.

Instructions to candidates

1. Sitting this examination implies that you agree to abide by the examination rules set down by Kinross College.
2. Answer the questions in the space provided.
3. You must be careful to confine your responses to the specific questions asked and to follow any instructions that are specific to a particular question.
4. A spare page is included at the end of this booklet. It can be used for planning your responses and/or as additional space if required to continue an answer.
 - (a) Planning: If you use the spare page for planning, indicate this clearly at the top of the page. If you choose to use lined paper for planning, ensure your name and the title is clearly printed.
 - (b) Continuing an answer: If you need to use the space to continue an answer give the page number. Fill in the number of the question (s) that you are continuing to answer at the top of the page.
5. This examination contributes towards your report. If you have any questions, please ask them during the ten-minute reading time.

Manage your time wisely. Always provide substantiation (evidence). Make sure that what you have written makes sense.

Note: Do not turn the page until you are asked to do so.

Topic	Marks
Earth Science- Tectonic Forces	34
Physics- energy	36
Total	70

Suggested time to complete 70 minutes

1. Name and describe the three types of movement of plates at plate boundaries. (6 marks)

Name	Description

2. Label the layers of diagram of the earth. (4 marks)

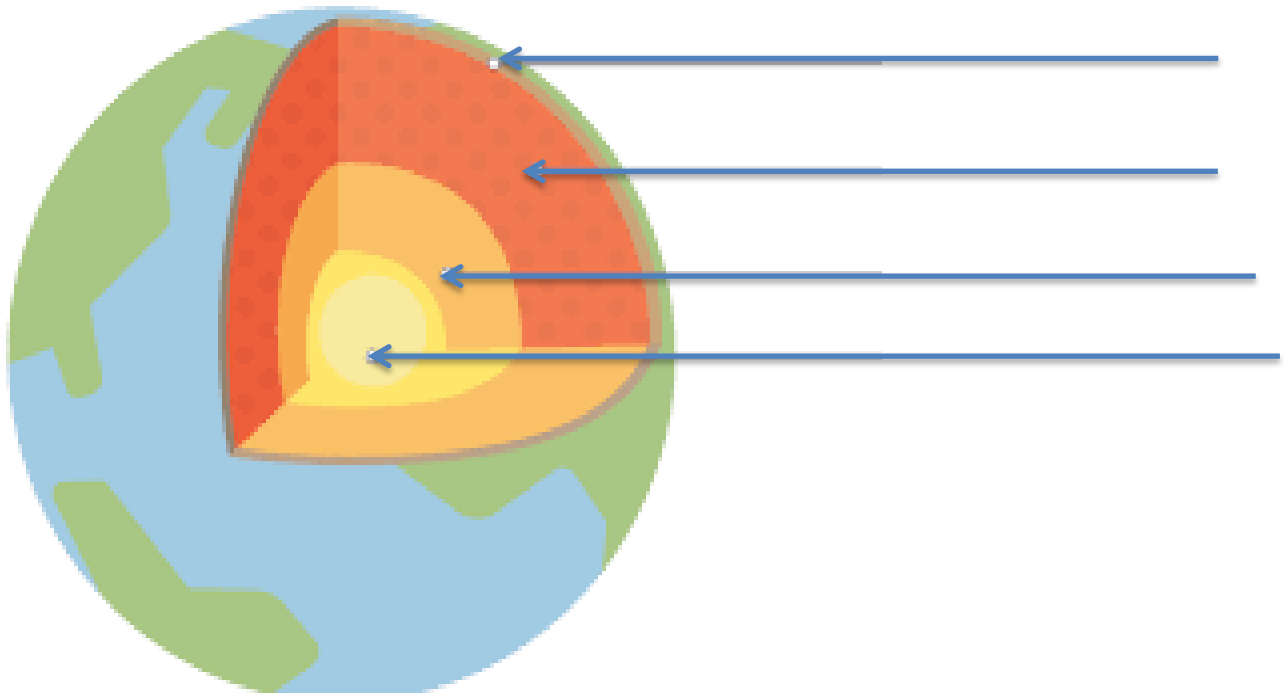

3. List 4 sources of scientific proof that support the theory of continental drift. (4 marks)

- i. _____
- ii. _____
- iii. _____
- iv. _____

6. On the graphing grid, opposite, make a Scatter Graph comparing earthquake magnitude against number of deaths (10 marks)

The table below lists the magnitude and death toll of 10 different Earthquakes:

Date	Place	Magnitude (Richter scale)	Number of Deaths (Thousands of people)
2008	China	7.9	374
1990	Iran	7.7	105
1976	Guatemala	7.5	76
2005	Pakistan	7.6	69
1970	Peru	7.9	50
2006	Indonesia	6.3	39
1995	Japan	6.9	37
2010	Haiti	7	30
1985	Mexico	8.1	30
2010	Chile	8.8	12

MARKS –
Title, 1 marks
Labels 2 marks
Units 2 marks
Scale 2 marks
Correctly plotted – 2 marks
Neatly labeled and drawn in pencil 1 mark

7. Does the graph, you have made for the previous question, show any relationship between the number of deaths and the magnitude of the earthquake? Explain your answer

(3 marks)

8. What do scientists call the energy waves that can be recorded when an earthquake occurs?

(1 mark)

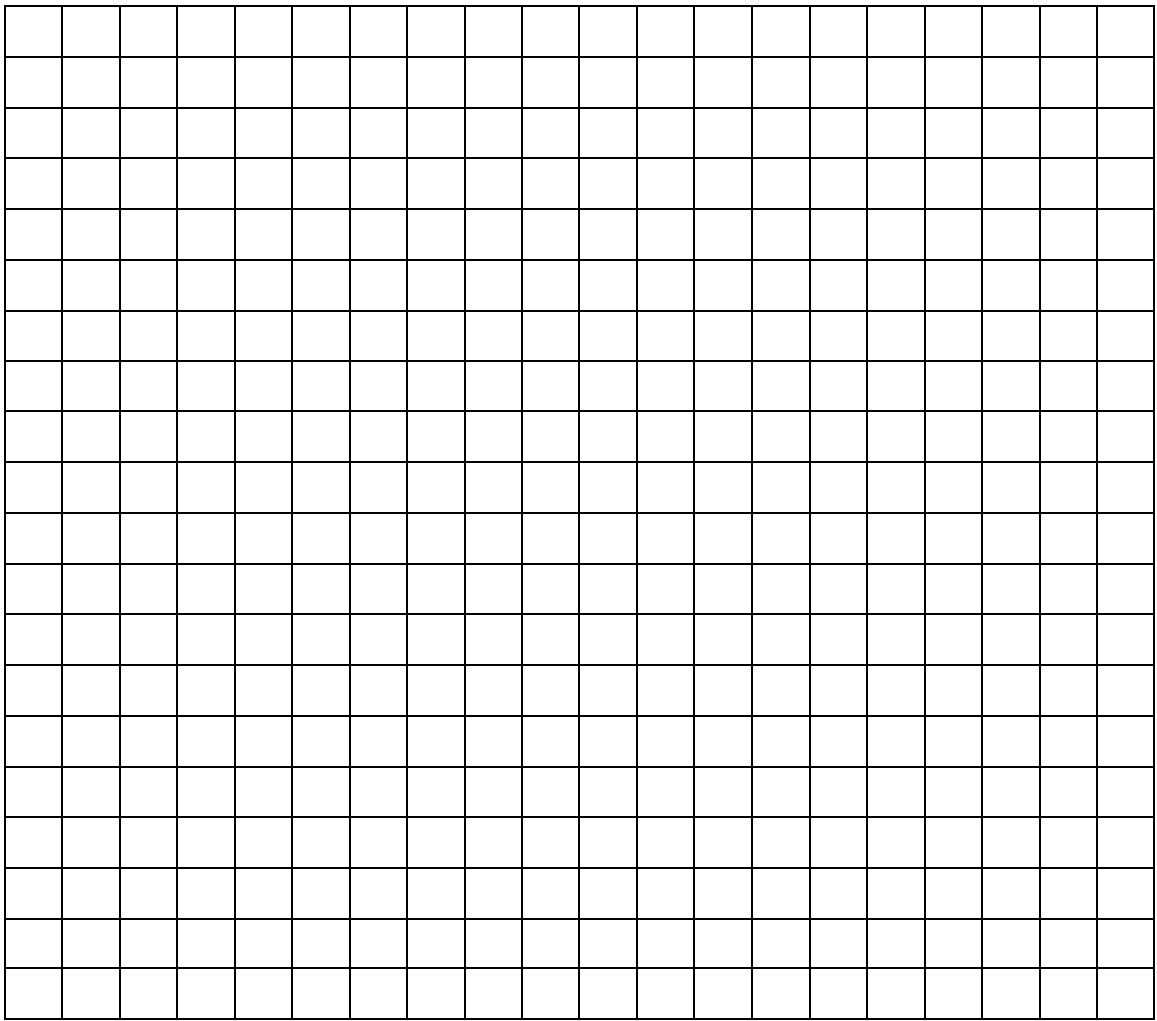

9. Name three ways heat moves and describe *what* it is moving through each time. (3 marks)

Name of heat movement	Name of what it is moving through and example of substance

- **Figure 9.1** - 2 Litres of cold water is heated in a saucepan A, and 1 litre of cold water is heated in an identical saucepan B for the same amount of time.

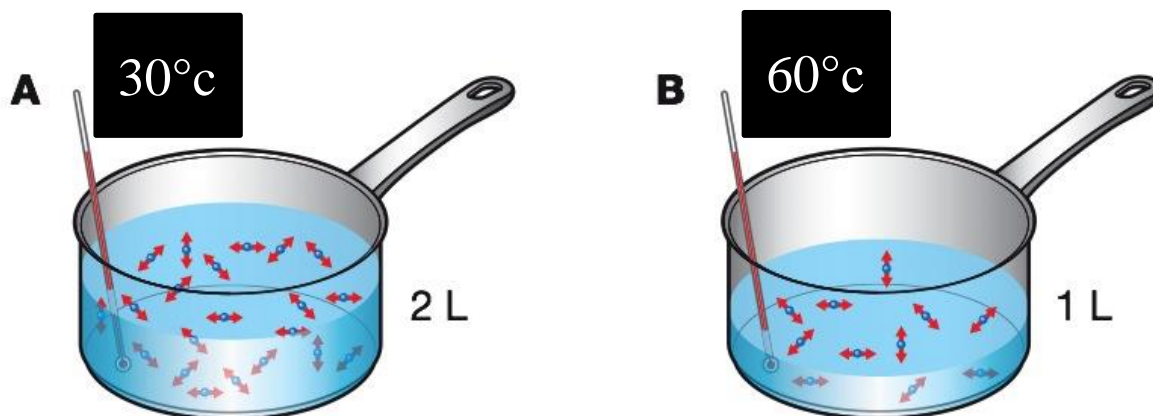

10. Thinking about the diagram and information given above, answer the following questions

Propose why the base of each saucepan is metal, but the handles are made from a tough plastic.	(1 mark)
Explain why the water in the saucepan B heats up faster.	(1 mark)
Compare the average kinetic energy of particles in each saucepan.	(2 marks)

11. Look at this unlabeled diagram of an eye below.

Name all of the numbered structures

(7 marks)

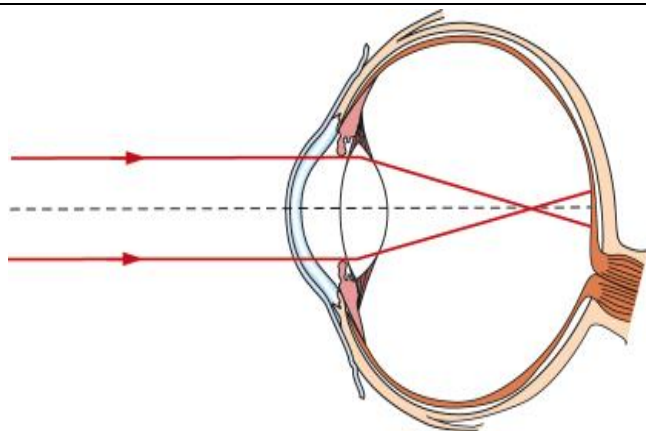
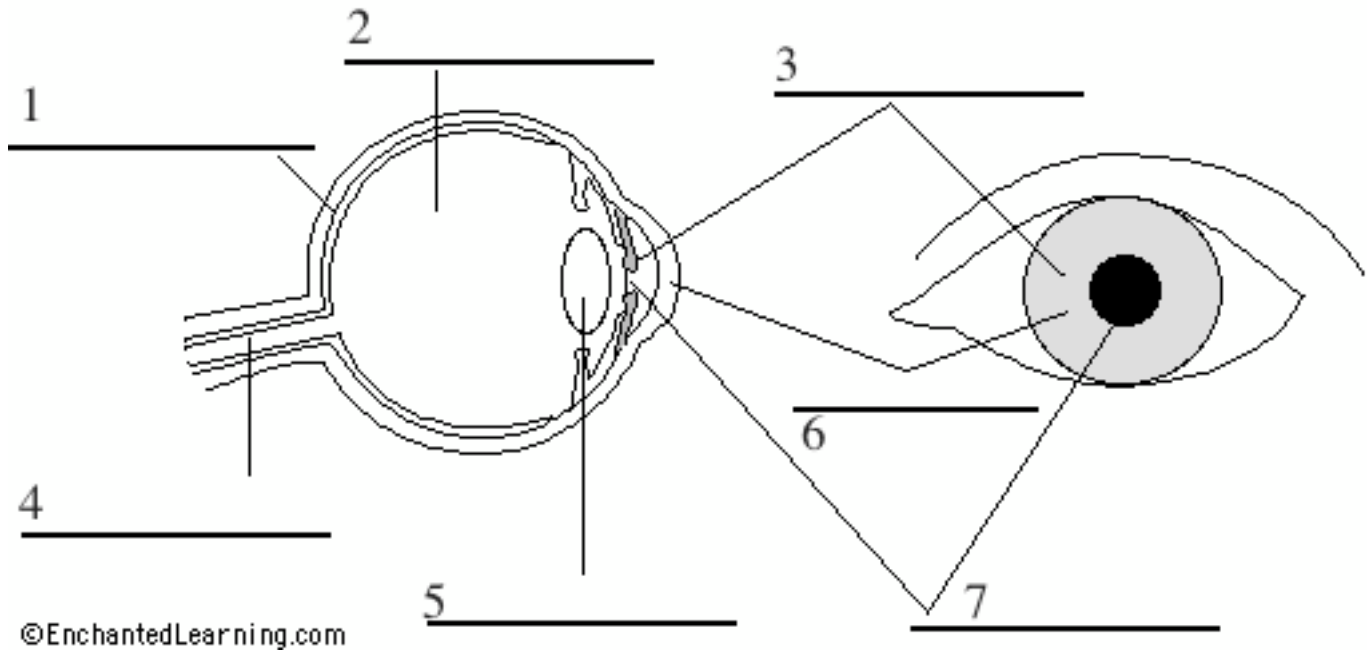

This diagram shows how Hannah's eye focuses light.

12

a. Identify Hannah's vision problem.

b. Propose the type of lens that could be used to help Hannah see clearly.

(2 marks)

Figure 13.1 The table shows the speed of sound at different temperatures.

Air Temperature (° C)	Speed of sound (m/s)
0	330
10	336
20	342
30	348
40	354

13. Complete the line Graph – with title, labels units and correct scale

(10 marks)

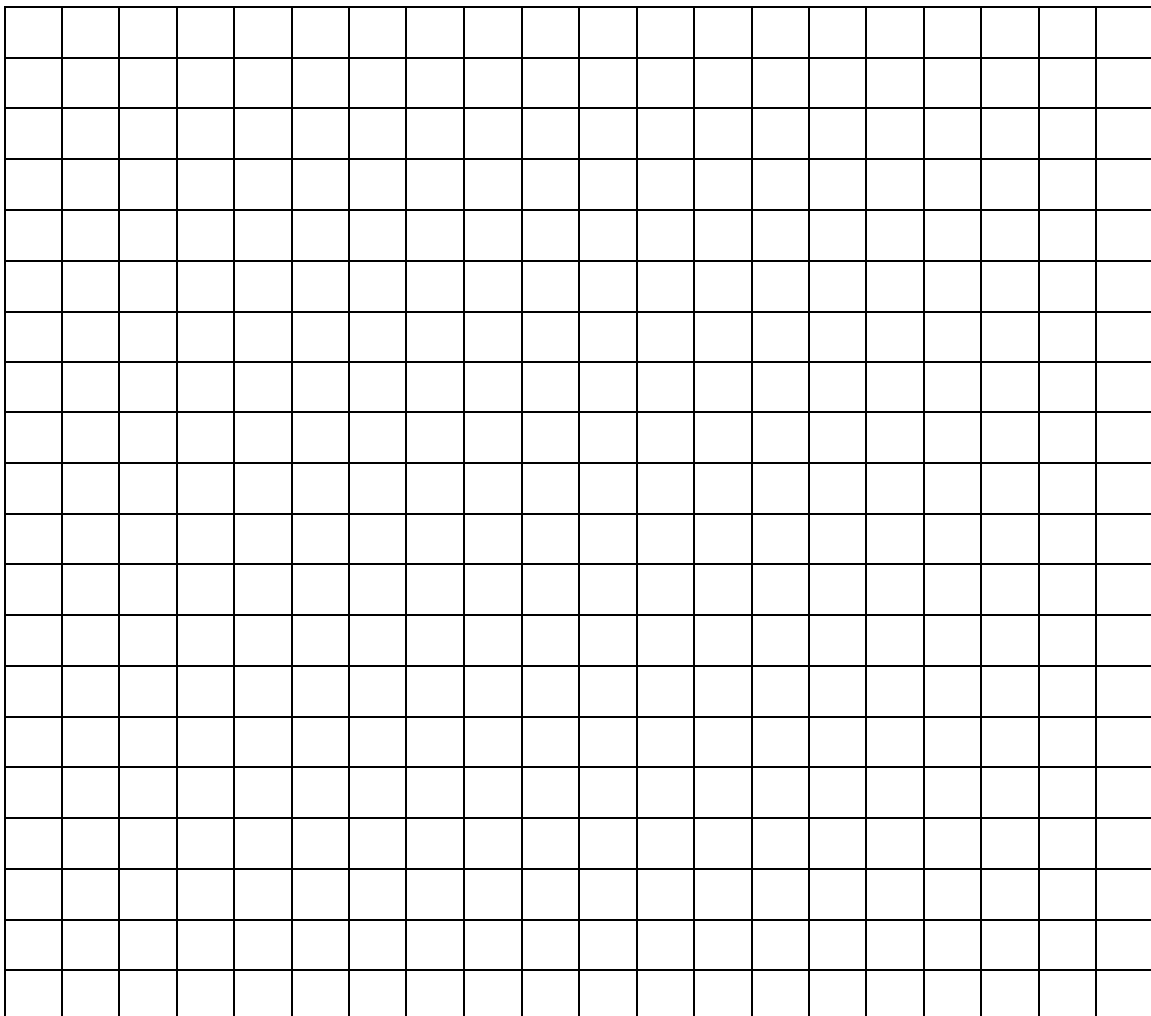

b) What is the speed of sound at 5 ° C ? _____ (1 mark)

c) What is the temperature of the air if the speed of sound is 351 m/s ? _____ (1 mark)

d) Describe the pattern shown by the graph you have drawn (for question 13). (2 marks)

Consider the following statements:

- Both **light** energy and **sound** energy travel as **waves**.
- When light energy passes through denser materials it slows down and is often stopped.
- When sound energy passes though denser substances it speeds up however it does not travel though space.

14. Discuss and explain this statement by comparing and contrasting sound energy and light energy. You will be given marks for Dot points and or diagrams if they labeled and appropriate.(6 marks)
